

# The Desired Memristor for Circuit Designers

Shahar Kvatinaky, Eby G. Friedman, Avinoam Kolodny, and Uri C. Weiser

## Abstract

Memristors are two-terminal devices with varying resistance, where the behavior is dependent on the history of the device. In recent years, different physical phenomena of resistive switching have been linked with the theoretical concept of a memristor, and several emerging memory devices (e.g., Phase Change Memory, Resistive RAM, STT-MRAM) are now considered as memristors. Memristors hold promise for use in diverse applications such as memory, digital logic, analog circuits, and neuromorphic systems.

Important characteristics of memristors include high speed, low power, good scalability, data retention, endurance, and compatibility with conventional CMOS in terms of manufacturing and operating voltages.

One interesting property of some memristors is a nonlinear response to current or voltage. Nonlinear memristors exhibit a current or voltage threshold, such that the resistance is affected only by currents or voltages which exceed the threshold, while the resistance of a linear memristor changes with small perturbations in device current.

Different applications exploit different characteristics of a memristor. In this article, the desired characteristics for different applications are presented from the viewpoint of an integrated circuit designer. Understanding the desired characteristics for different applications can assist device and material engineers in providing the appropriate behavior when developing memristive devices, thereby optimizing these devices for different applications.

## I. Introduction

Memristors have many different facets. A memristor can be considered as the theoretical missing fundamental element originally proposed by Leon Chua in 1971 [1]. This theoretical device is a resistor with varying resistance, where the resistance

## Memristors: Theory and Applications

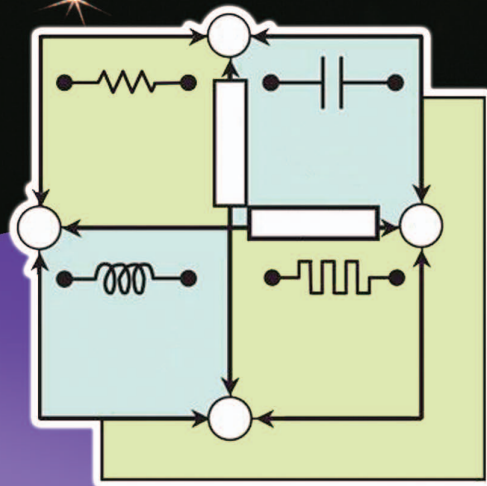

© JOHN FOX & WIKIMEDIA COMMONS/KIOSHIS

changes according to the charge passed through the memristor over its entire history. Chua extended the theory of memristors to 'memristive devices' in 1976 with his student, Steve (Sung Mo) Kang [2]. A memristive device is basically any resistor with a resistance that only changes due to the voltage across the device or, alternatively, the current flowing through the device. Since the resistance does not change when there is no voltage applied across the device, memristive devices are nonvolatile. It is acceptable to use the term 'memristor' to describe a 'memristive device.'

Since Hewlett Packard Laboratories announced the fabrication of a working memristor by electrical conduction in titanium oxide ( $\text{TiO}_2$ ) in 2008 [3], it has become popular to link different physical phenomena of resistive switching with the term memristor. These devices include a large variety of oxides, also named Resistive RAM (RRAM). Additional emerging memory devices (e.g., Phase Change Memory and STT-MRAM) may also be considered as memristors since these devices are basically nonvolatile two-terminal devices with varying

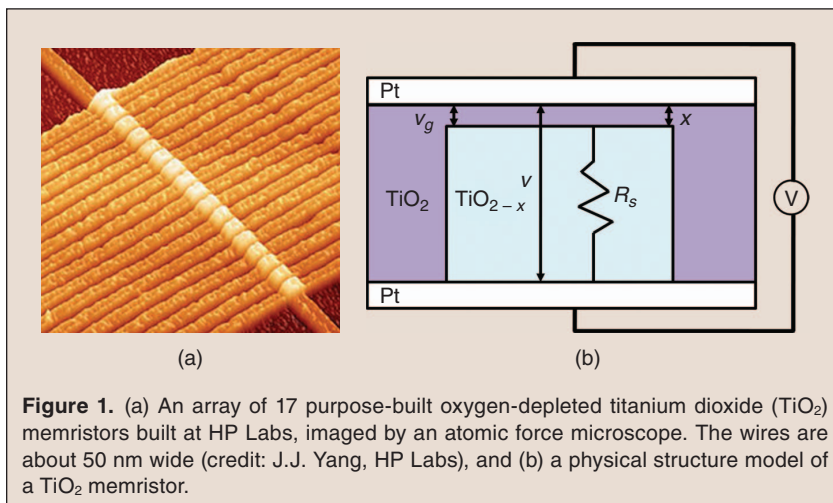

**Figure 1.** (a) An array of 17 purpose-built oxygen-depleted titanium dioxide ( $\text{TiO}_2$ ) memristors built at HP Labs, imaged by an atomic force microscope. The wires are about 50 nm wide (credit: J.J. Yang, HP Labs), and (b) a physical structure model of a  $\text{TiO}_2$  memristor.

resistance. In this article, memristors are considered in their broadest meaning—any two-terminal device with memory capability, which is represented by a varying resistance. An array of  $\text{TiO}_2$  memristors and a schematic of the physical structure of a single device are shown in Figure 1.

## II. The Desired Memristor

Using memristors as storage elements in a memory is an obvious choice. Actually, most emerging memory technologies, which are considered as potential replacements for Flash, DRAM, and SRAM, are based on memristors. These technologies are somewhat immature and are not yet fully commercialized. Toshiba and Sandisk are currently sampling 4 GB RRAM memory circuits [4], Micron and Samsung are selling 16 MB PCM [5], and Everspin recently debuted an 8 MB STT-MRAM [6]. Memristors are, however, much more than memory devices. The ability to control and modify their current-voltage characteristics can be utilized for performing a variety of computational operations. Memristors hold promise for use in diverse applications such as digital and analog circuits, and neuromorphic systems.

Since memristor technology is currently immature, standardization of the characteristics of memristors remains to be done. The desired characteristics may differ for different applications. In this article, the desired characteristics of memristors are described for different applications from the viewpoint of an integrated circuit designer. Understanding the desired characteristics for different applications can assist device and material engineers in providing

the appropriate behavior when developing memristive devices, thereby optimizing these devices for different applications.

## III. Memory

The speed, power consumption, data retention, and endurance of memristors are better than Flash memory for all emerging memristive technologies, and are comparable to DRAM and SRAM for certain memristive technologies. Speed is determined by the write time which currently varies from tens of nanoseconds (PCM) to hundreds of picosec-

onds (RRAM). Endurance is determined by the number of writes to a device without affecting the stored data, and currently varies from hundreds of millions of writes (PCM) to an unlimited number of writes (STT-MRAM). All emerging memory technologies satisfy the industrial standard of ten year data retention. STT-MRAM, however, still suffers degradation in data retention for technologies below 45 nm. A summary of the required characteristics for memory applications is listed in Table 1.

One interesting property of some memristors is a nonlinear response to current or voltage. Nonlinear memristors exhibit a current or voltage threshold, such that the resistance is not affected by relatively small currents or voltages, while the resistance of a linear memristor will change due to any change in device current. In the original publication by Hewlett Packard in 2008 [3], a linear memristor was presented. Practical memristors, however, seem to behave nonlinearly, although the nonlinearity varies for different materials and technologies. Current-voltage curves of linear and nonlinear memristor are shown in Figure 2.

Due to excellent scalability and fast speed, memristors are a potential replacement for Flash memory in SSD, which requires dense memory, as well as DRAM and SRAM for main memory and cache memory, which require relatively fast memory with unlimited writes. Memristors therefore provide an opportunity for 'universal memory'—a single technology for all memory hierarchies. Memristors are by their definition nonvolatile devices. Using memristors within caches and main memory will make these memories nonvolatile, dramatically changing the manner in which these memories

Shahar Kvatinsky, Avinoam Kolodny, and Uri C. Weiser are with Technion—Israel Institute of Technology, Haifa 3200, Israel. Eby G. Friedman is with the University of Rochester, Rochester, New York, 14627 USA.

are applied in modern computing systems.

Memory is an analog circuit behaving digitally, in which the resistance of the memristor typically represents a binary value. A low resistance is typically considered as a ‘logical one’ and a high resistance is treated as a ‘logical zero.’ A high ratio between the high and low resistance (usually named, respectively,  $R_{OFF}$  and  $R_{ON}$ ) is therefore desirable. It is also desirable to provide a non-destructive read mechanism, but the read operation in memristors may induce drift in the stored state. The drift requires occasionally refreshing the memory. The device design process should therefore consider the trade off between speed and robustness due to this state drift phenomenon. A preferred memristor would therefore be highly nonlinear, with a well-defined and abrupt threshold between the two distinct states.

In memory applications, it is also possible to write more than one bit into a single memristor if the resistance of the device can be quantized into multiple levels. The difference among the different data must be carefully determined. To successfully store more than one bit within a memristor, it is crucial to maintain a high ratio between  $R_{OFF}$  and  $R_{ON}$  to provide a wide range of resistance. It is also preferable that a linear memristive device successfully write the desired value with similar write pulses, or, alternatively, that a write mechanism allows a different and distinct write operation for different data. In PCM, for example, the write operation uses

**Table 1.**  
Requirements of memristors for memory [11].

	Speed (Write Time) [Seconds]	Endurance [# Writes]	Energy Per Bit [Joule]	Nonvolatility
Storage (flash replacement)	0.1 to 10 $\mu$	$10^5$	10 n	Yes
Main Memory (DRAM replacement)	10 n	$> 10^{15}$	5 p	No
Cache (SRAM replacement)	0.3 to 1 n	$> 10^{15}$	5 p	No

a different magnitude and duration of applied current to write different data, as depicted in Figure 3.

#### IV. Computational Logic with Memristors

Another application of memristors is computational logic, where memristors are used as logic gates. Several different logic families have been developed that use memristors as fundamental elements within logic gates. In certain logic families, the logical state is represented as a resistance, as in memory, and the result of the logical operation is also stored as a resistance in a memristor. These logic families can therefore be used for *logic within memory*, and require similar memristor characteristics as in memory, namely, nonlinear memristors with well-defined thresholds are preferable. An example of these logic families is material implication (IMPLY) [7], as shown in Figure 4. In other logic families, the logical state is represented as a voltage level, as in CMOS logic. These logic families are useful for *hybrid CMOS-memristor*

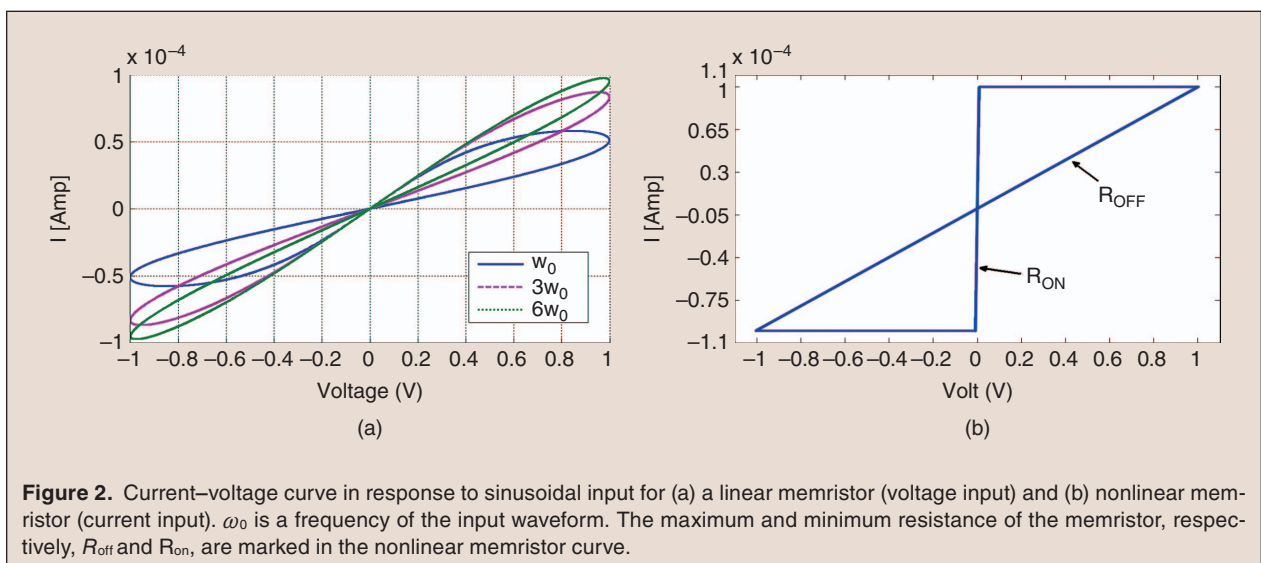

**Figure 2.** Current–voltage curve in response to sinusoidal input for (a) a linear memristor (voltage input) and (b) nonlinear memristor (current input).  $\omega_0$  is a frequency of the input waveform. The maximum and minimum resistance of the memristor, respectively,  $R_{off}$  and  $R_{on}$ , are marked in the nonlinear memristor curve.

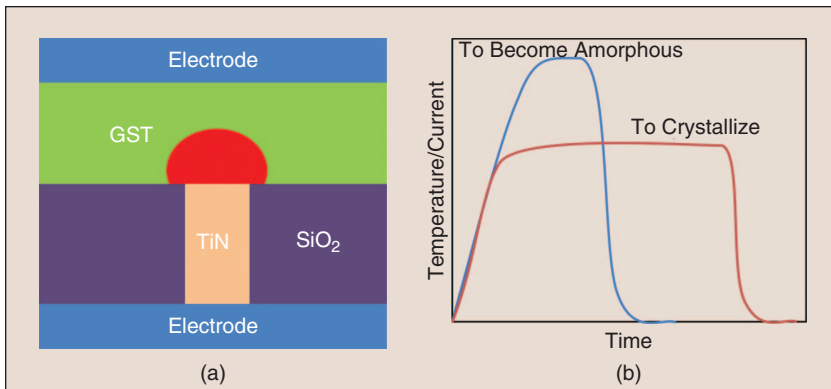

**Figure 3.** Phase change memory (PCM) (a) physical structure. A resistor made of TiN acts as a heater and heats the active area (marked in red). The active area heats the GST (chalcogenide glass), which changes its phase between crystalline and amorphous states. Crystalline state has better conductivity than amorphous state. (b) The write operation is done by flowing current in different shapes where high current (temperature) for a short period changes the phase to amorphous and relatively low current for a long period changes the phase to crystalline.

(MRL) [8], as shown in Figure 5. It is also possible to use memristors as configurable switches in PLA and FPGA [9], as shown in Figure 6. For these applications, the memristors replace the standard programmable switches, commonly placed within the FPGA as CMOS switch boxes. High and low resistances are treated, respectively, as an ‘open’ and ‘closed’ switch. In these applications, the configuration phase is separate from the operation. The resistance of the memristors therefore does not change during operation and a nonlinear memristor with a threshold is necessary. A significant ratio between the high and low resistance is also highly desirable.

logic, where the critical characteristics of the memristors are their high density and compatibility with standard CMOS, both in fabrication and voltage levels. These logic families increase the logic density, where, for the same area, the number of logic gates is significantly higher. For these logic families, a linear memristor is preferable to reduce power consumption and delay. An example of these logic families is Memristor Ratioed Logic

### V. Analog Circuits and Neuromorphic Systems

In applications using analog circuits and neuromorphic systems (electronic circuits that mimic the brain), the resistance typically requires a continuous value. Memristors can be used as configurable devices where the resistance of the device is initialized by a specific procedure, different from typical circuit operation [10]. During regular circuit operation, the memristor

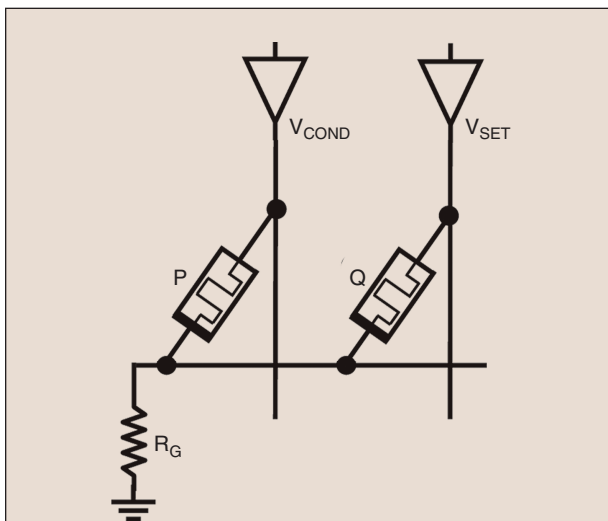

**Figure 4.** Schematic of a memristor-based material implication (IMPLY) logic gate. IMPLY gate consists of two memristors and a resistor. The memristors can be part of a memristor-based crossbar used for memory. The input and output variables of the IMPLY logic gate are the stored logical state of the memristors, represented by their initial and final resistance, where high and low resistance are considered, respectively, as logical zero and one.

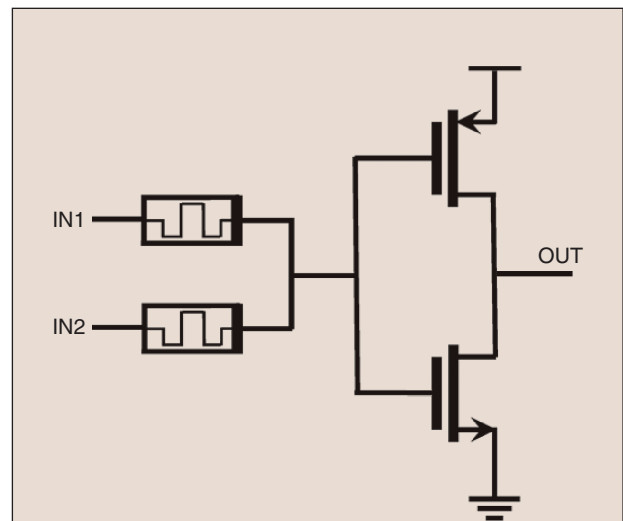

**Figure 5.** An example of hybrid memristor-CMOS logic—memristor ratioed logic (MRL). An MRL NAND logic gate consists of two memristors and two CMOS transistors. The memristors act as a logical AND gate and are connected to a CMOS-based inverter. The logical input and output variables are represented by voltages, as in conventional CMOS logic.



behaves as a simple resistor. The properties of the circuit can be tuned. A configurable amplifier is shown in Figure 7, where the gain and bandwidth of an amplifier vary due to the configurable resistance. In these applications, it is desirable for the memristor to behave as a nonlinear nondestructive device, similar to the read mechanism in digital applications. Memristors can also be used as computational elements in analog circuits, such as analog counters and sensors. In these circuits, it is desirable for the memristor to maintain a linear behavior, where the local current changes the resistance of the memristor.

In neural networks, memristors mimic the role of synapses, such that each device may interact with other devices throughout the system. Several models exist for using memristors in neuromorphic systems. Usually, machine learning algorithms are executed in these systems. A threshold is useful to disable the learning operation. During the learning operation, the resistance of the memristor is changed based on the input of the system, usually a voltage pulse. It is desirable for the same input to change the resistance of the memristor the same every time. Nonlinear memristors require the change in resistance to be significantly different for the same input with a different initial resistance, greatly complicating the learning process.

## VI. Conclusions

In summary, memristors provide an inspiring variety of opportunities for electronics. Memristor technology is still immature and the device characteristics can vary a great deal. However, significant focus within academia and industry is currently taking place to develop and commercialize this exciting new technology. In this article, certain desirable characteristics of memristors are described for an assortment of applications. It is intended that device and material engineers will consider the requirements for these devices from the point of view of an integrated circuit designer, and develop devices suitable for specific applications, opening a new era of memory intensive computing.

**Shahar Kvatinsky** is a Ph.D. candidate at the electrical engineering department at the Technion—Israel

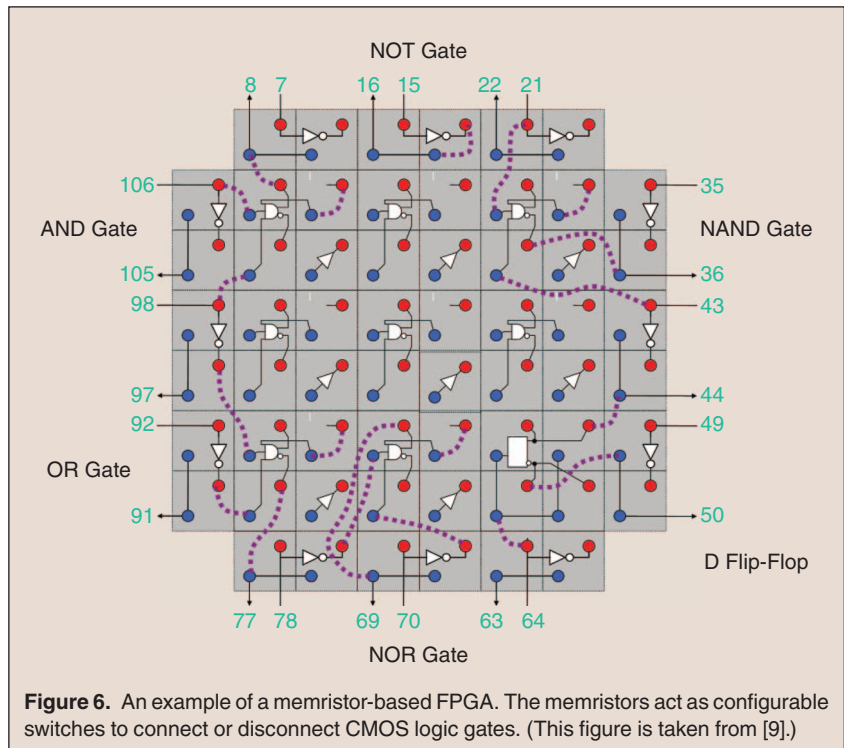

**Figure 6.** An example of a memristor-based FPGA. The memristors act as configurable switches to connect or disconnect CMOS logic gates. (This figure is taken from [9].)

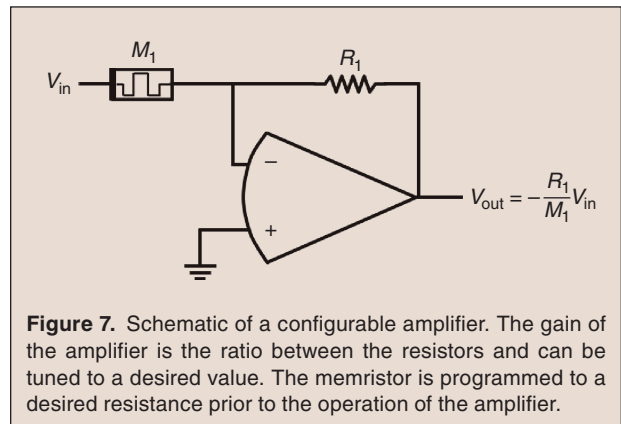

**Figure 7.** Schematic of a configurable amplifier. The gain of the amplifier is the ratio between the resistors and can be tuned to a desired value. The memristor is programmed to a desired resistance prior to the operation of the amplifier.



Institute of Technology. He received his B.Sc. in computer engineering and applied physics, and an MBA at 2009 and 2010, respectively, both from the Hebrew University of Jerusalem. Prior to his Ph.D. studies he worked for Intel as a circuit designer.

**Eby G. Friedman** received the B.S. degree from Lafayette College in 1979, and the M.S. and Ph.D. degrees from the University of California, Irvine, in 1981 and 1989, respectively, all in electrical engineering. From 1979 to 1991, he was with Hughes Aircraft Company,



rising to the position of manager of the Signal Processing Design and Test Department, responsible for the design and test of high performance digital and analog ICs. He has been with the Department of Electrical and Computer Engineering at the University of Rochester since 1991, where he is a Distinguished Professor, and the Director of the High Performance VLSI/IC Design and Analysis Laboratory. He is also a Visiting Professor at the Technion—Israel Institute of Technology. His current research and teaching interests are in high performance synchronous digital and mixed-signal microelectronic design and analysis with application to high speed portable processors and low power wireless communications. He is the author of over 400 papers and book chapters, 11 patents, and the author or editor of 15 books in the fields of high speed and low power CMOS design techniques, 3-D design methodologies, high speed interconnect, and the theory and application of synchronous clock and power distribution networks. Dr. Friedman is the Regional Editor of the *Journal of Circuits, Systems and Computers*, a Member of the editorial boards of the *Analog Integrated Circuits and Signal Processing*, *Microelectronics Journal*, *Journal of Low Power Electronics*, *Journal of Low Power Electronics and Applications*, and *IEEE Journal on Emerging and Selected Topics in Circuits and Systems*, Chair of the *IEEE Transactions on Very Large Scale Integration (VLSI) Systems* steering committee, and a Member of the technical program committee of a number of conferences. He previously was the Editor-in-Chief of the *IEEE Transactions on Very Large Scale Integration (VLSI) Systems*, a Member of the editorial board of the *Proceedings of the IEEE*, *IEEE Transactions on Circuits and Systems II: Analog and Digital Signal Processing*, and *Journal of Signal Processing Systems*, a Member of the Circuits and Systems (CAS) Society Board of Governors, Program and Technical chair of several IEEE conferences, and a recipient of the University of Rochester Graduate Teaching Award and a College of Engineering Teaching Excellence Award. Dr. Friedman is a Senior Fulbright Fellow and an IEEE Fellow.



**Avinoam Kolodny** received his doctorate in microelectronics from Technion—Israel Institute of Technology in 1980. He joined Intel Corporation, where he was engaged in research and development in the areas of device physics, VLSI circuits, electronic design automation, and

organizational development. He has been a member of the Faculty of Electrical Engineering at the Technion since 2000. His current research is focused primarily on interconnects in VLSI systems, at both physical and architectural levels.



**Uri C. Weiser** is a visiting Professor at the Electrical Engineering department, Technion IIT and acts as an advisor at numerous startups. He received his bachelor and master degrees in EE from the Technion and a Ph.D. in CS from the University of Utah, Salt Lake City. Uri worked at Intel from 1988–2006. At Intel, Uri initiated the definition of the first Pentium processor, drove the definition of Intel’s MMX technology, invented (with A. Peleg) the Trace Cache, he co-managed and established the Intel Microprocessor Design Center at Austin, Texas and later initiated an Advanced Media applications research activity. Uri was appointed Intel Fellow in 1996, in 2002 he became IEEE Fellow and in 2005 ACM Fellow. Prior to his career at Intel, Uri worked for the Israeli Department of Defense as a research and system engineer and later with National Semiconductor Design Center in Israel, where he led the design of the NS32532 microprocessor. Uri was an Associate Editor of *IEEE Micro Magazine* (1992–2004) and was Associate Editor of *Computer Architecture Letters*.

## References

- [1] L. O. Chua, “Memristor: The missing circuit element,” *IEEE Trans. Circuit Theory*, vol. 18, no. 5, pp. 507–519, Sept. 1971.
- [2] L. O. Chua and S. M. Kang, “Memristive devices and systems,” *Proc. IEEE*, vol. 64, no. 2, pp. 209–223, Feb. 1976.
- [3] D. B. Strukov, G. S. Snider, D. R. Stewart, and R. S. Williams, “The missing memristor found,” *Nature*, vol. 453, pp. 80–83, May 2008.
- [4] [Online]. Available: <http://www.theinquirer.net/inquirer/news/2234321/sandisk-and-toshiba-dabble-in-ram>
- [5] [Online]. Available: <http://www.micron.com/products/phase-change-memory>
- [6] [Online]. Available: [http://www.everspin.com/PDF/ST-MRAM\\_Press\\_Release.pdf](http://www.everspin.com/PDF/ST-MRAM_Press_Release.pdf)
- [7] S. Kvatinsky, E. G. Friedman, A. Kolodny, and U. C. Weiser, “Memristor-based IMPLY logic design procedure,” in *Proc. IEEE Int. Conf. Computer Design*, Oct. 2011, pp. 142–147.
- [8] S. Kvatinsky, N. Wald, G. Satat, E. G. Friedman, A. Kolodny, and U. C. Weiser, “Hybrid CMOS-memristor logic,” *IEEE Trans. Circuits Syst. II, Exp. Briefs*, submitted for publication.
- [9] Q. Xia, W. Robinett, M. W. Cumbie, N. Banerjee, T. J. Cardinali, J. J. Yang, W. Wu, X. Li, W. M. Tong, D. B. Strukov, G. S. Snider, G. Medeiros-Riberio, and R. S. Williams, “Memristor-CMOS hybrid integrated circuits for reconfigurable logic,” *Nano Lett.*, vol. 9, no. 10, pp. 3640–3645, Oct. 2009.
- [10] Y. V. Pershin and M. Di Ventra, “Practical approach to programmable analog circuits with memristors,” *IEEE Trans. Circuits Syst. I. Reg. Papers*, vol. 57, no. 8, pp. 1857–1864, Sept. 2010.
- [11] D. Bondurant, B. Engel, and J. Slaughter, “MRAM: The future of non-volatile memory?” *Portable Design*, July 2008.